

# I-PRO 2 BOWLS, WITH MECHANICAL CONTROL



I-PRO2M

**Ref: 562939  
(I-PRO2M)**

Slush and sherbet machine, with 2x11-litres lighted and insulated bowls  
I-Tank, mechanical control, refrigerant gas R290

## General Features

I-PRO 2 MECHANICAL is a professional slush machine with n. 2 I-Tank insulated bowls, 11 litres each, and mechanical control.

Every detail has been studied to create a unique equipment thanks to the numerous patents and innovations available for this model.

This equipment has the I-Tank insulated tank as standard. The shape of the tanks, which work independently, guarantees a natural mixing effect for an optimal consistency of the product.

The look of this equipment is modern and eye-catching, thanks to the LED-light system that illuminates the product inside the tank.

The equipment can dispense: slushies, milkshakes, cold drinks and frozen cocktails.

I-PRO is an ideal slush machine for bars, amusement parks, fast food chains, kiosks, restaurants, water parks and much more.

CRATHCO

# I-PRO 2 BOWLS, WITH MECHANICAL CONTROL

## Specifications

- The ITANK™ Technology prevents ice accumulation on the outer side of the bowl, reducing condensation and increasing the cooling power of the machine.
- Ideal for the production of slush.
- Bowl shape allows a natural mixing action to ensure an optimum consistency of the product.
- Customizable lid merchandiser and back graphic.
- Ideal for operators who want an innovative and distinctive equipment. Mechanical keypad allows for setting of cooling and defrost modes.
- It is possible to customize the graphics on the front, on the lid and on the back (subject to negotiation).

## Construction

- Electromechanical control.
- Sliding drip tray.
- Optional Autofill Lid System available: for the automatic filling of the tanks

# I-PRO 2 BOWLS, WITH MECHANICAL CONTROL

## Electric

|                        |                          |
|------------------------|--------------------------|
| Supply voltage:        | 220-240 V / 1 ph / 50 Hz |
| Electrical power max.: | 0.78 kW                  |
| Current consumption:   | 4.2 Amps                 |
| Plug type:             | CE-SCHUKO                |

## Key Information:

|                     |        |
|---------------------|--------|
| Number of bowls:    | 2      |
| Bowl's capacity:    | 11 lt  |
| Control board:      |        |
| Dimensions, Width:  | 400 mm |
| Dimensions, Depth:  | 580 mm |
| Dimensions, Height: | 870 mm |
| Net weight:         | 60 kg  |

## Refrigeration Data

|                  |      |
|------------------|------|
| Refrigerant gas: | R290 |
|------------------|------|

## Certifications



The company reserves the right to make modifications to the products without prior notice. All information correct at time of printing.

2026.03.31

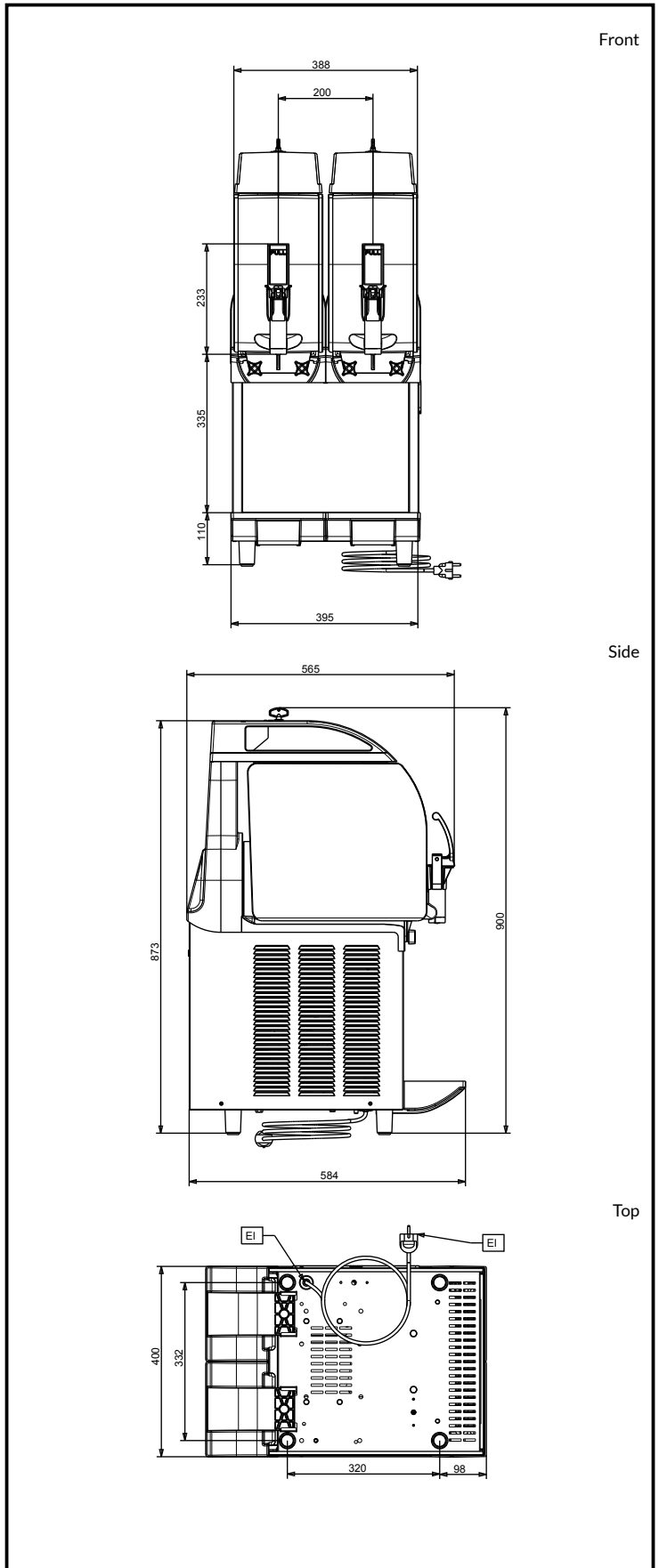

**CRATHCO**

www.crathco.drink-systems.com  
infocrathco@electroluxprofessional.com